

REVISIONS				
LTR	DESCRIPTION	DATE	REVISED	APPROVED

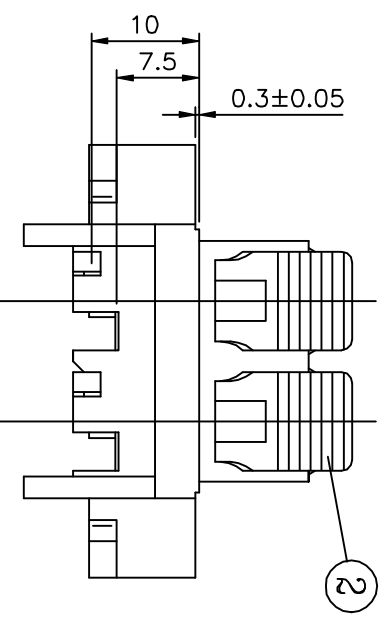
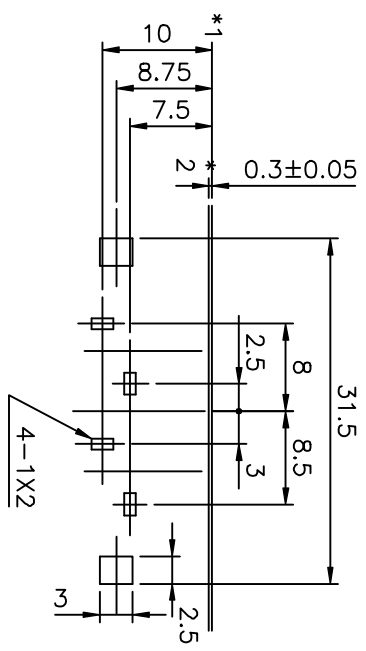
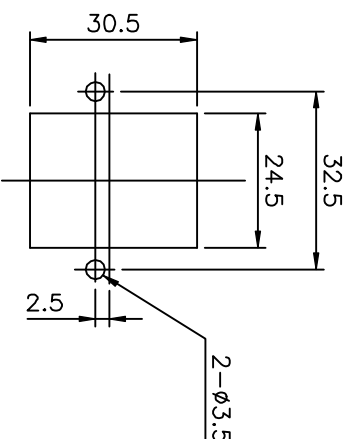
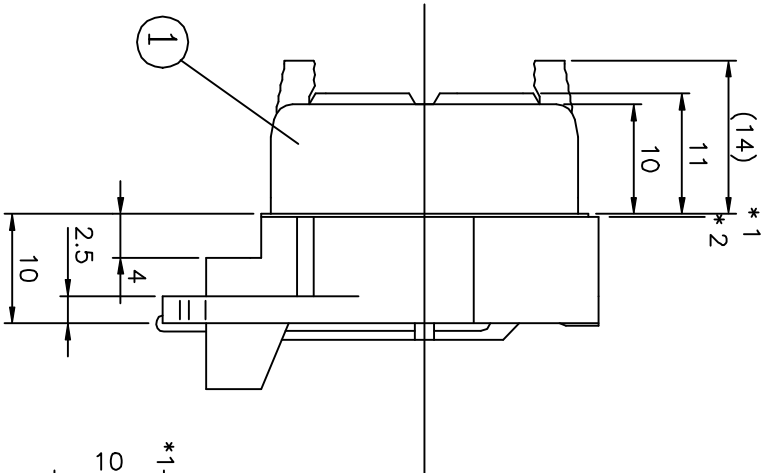
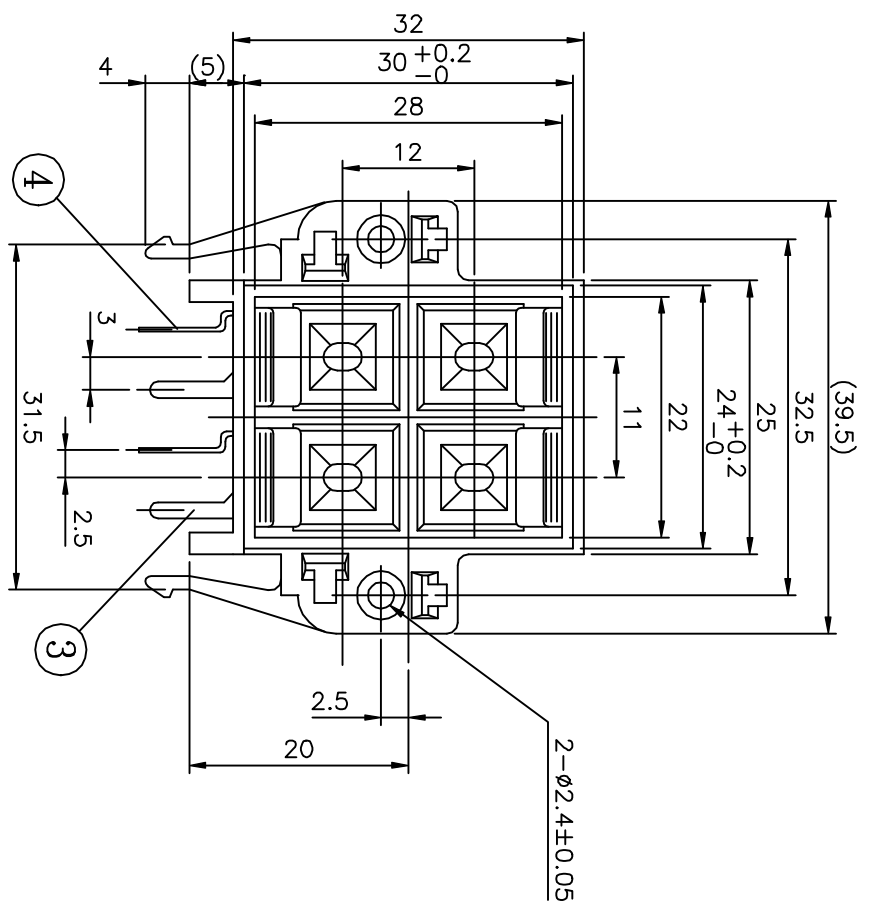

4	CONTACT SPRING	2	C5191R-EH t=0.3	Pb-Sn PLATED
3	CONTACT SPRING	2	C5191R-EH t=0.3	Pb-Sn PLATED
2	PUSH PLATE	4	POM	94HB
1	HOUSING	1	ABS (BLACK)	94HB
LTR	PART NAME	QTY	MATERIAL (THICK, COLOR)	REMARK
DWN	DATE	SCALE	2/1	NAME
DSND	KEVIN KUNG	DATE	1993.07.27	PUSH TERMINAL BOARD
CHKD	DATE	3RD ANGLE PROJECTION	DATE	CAT. NO.
APVD	DATE	UNIT: mm	DATE	HSP-324V

UNLESS OTHERWISE SPECIFIED, TOLERANCE ON DECIMAL: ±0.3 FRACTIONS: ANGLES:

SINGATRON ENTERPRISE CO., LTD. (U.S.A.) DWN. NO. A-324