

REVISIONS				
LTR	DESCRIPTION	DATE	REVISED	APPROVED

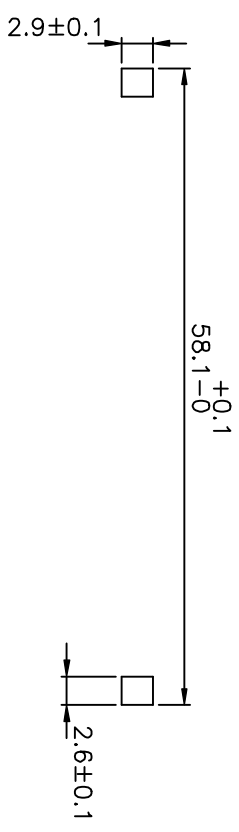
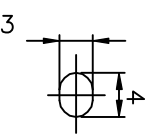
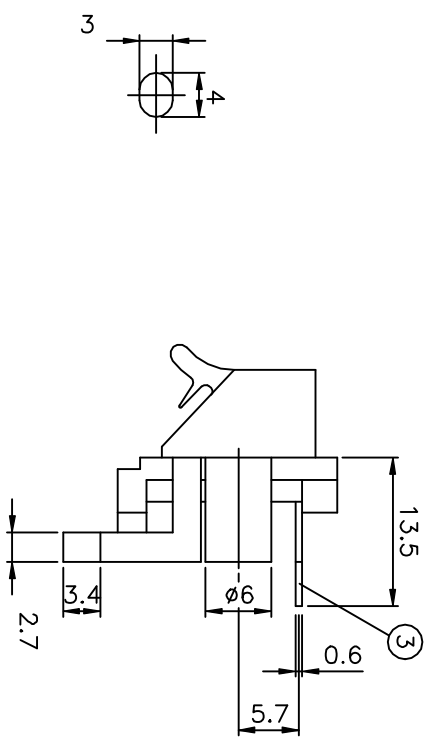
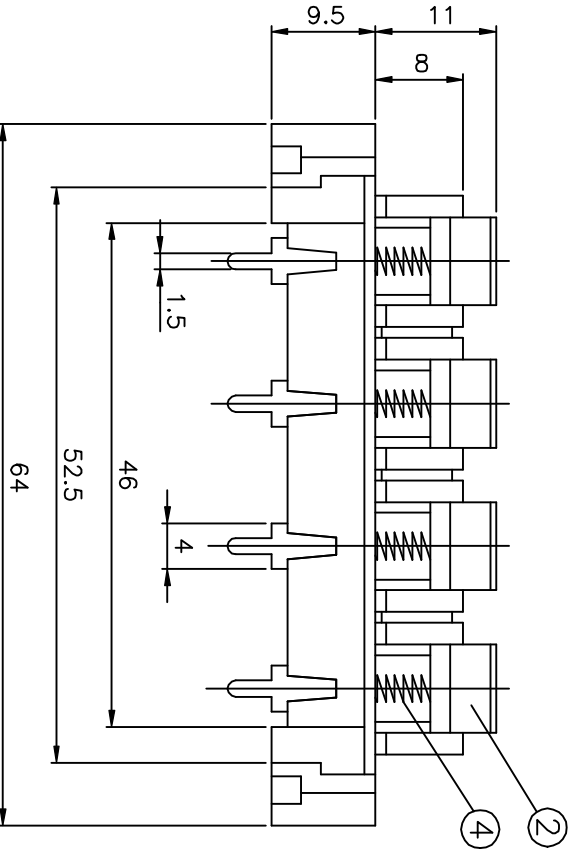
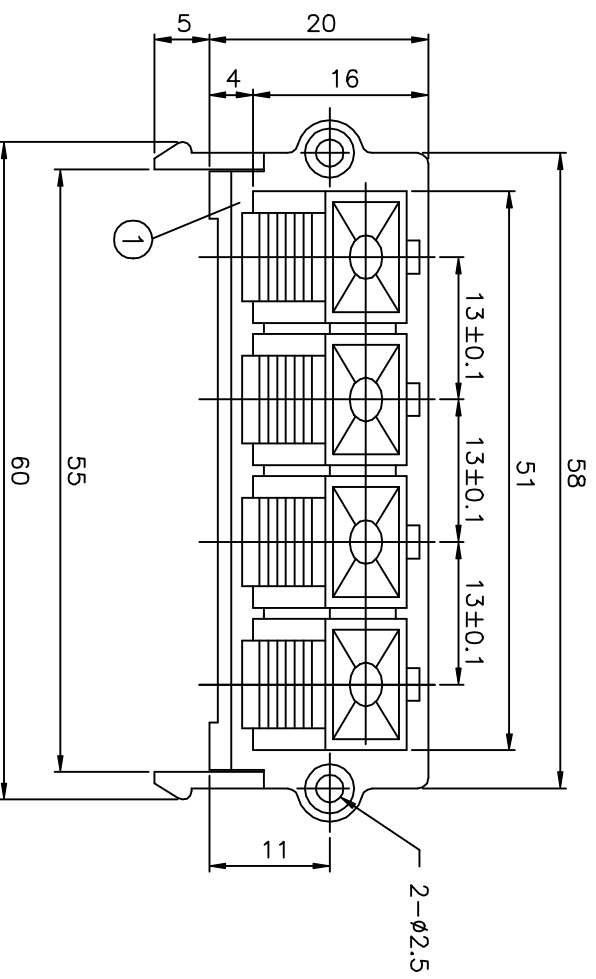

4	SPRING	4	SWC ∅0.55		
3	CONTACT	4	C2680 , t=0.6	MB : Cu	Pb-Sn PLATED
2	PUSH PLATE	4	ABS , UL-94HB		
1	HOUSING	1	ABS , UL-94HB		
LTR	PART NAME	QTY	MATERIAL(THICK,COLOR)	REMARK	
DSND	M.L.CHANG	DATE	1992.09.17	SCALE 2 / 1	NAME
DWN	H.Y.Chou	DATE	2000.02.14	3RD ANGLE PROJECTION	PUSH TERMINAL
CHKD		DATE		UNIT: mm	CAT. NO.
APVD		DATE			HSP-114HS-

UNLESS OTHERWISE SPECIFIED, TOLERANCE ON DECIMAL: ±0.3 FRACTIONS: ANGLES:

SINGATRON ENTERPRISE CO., LTD. (U.S.A.)

DWN.NO. A-114HS 001